

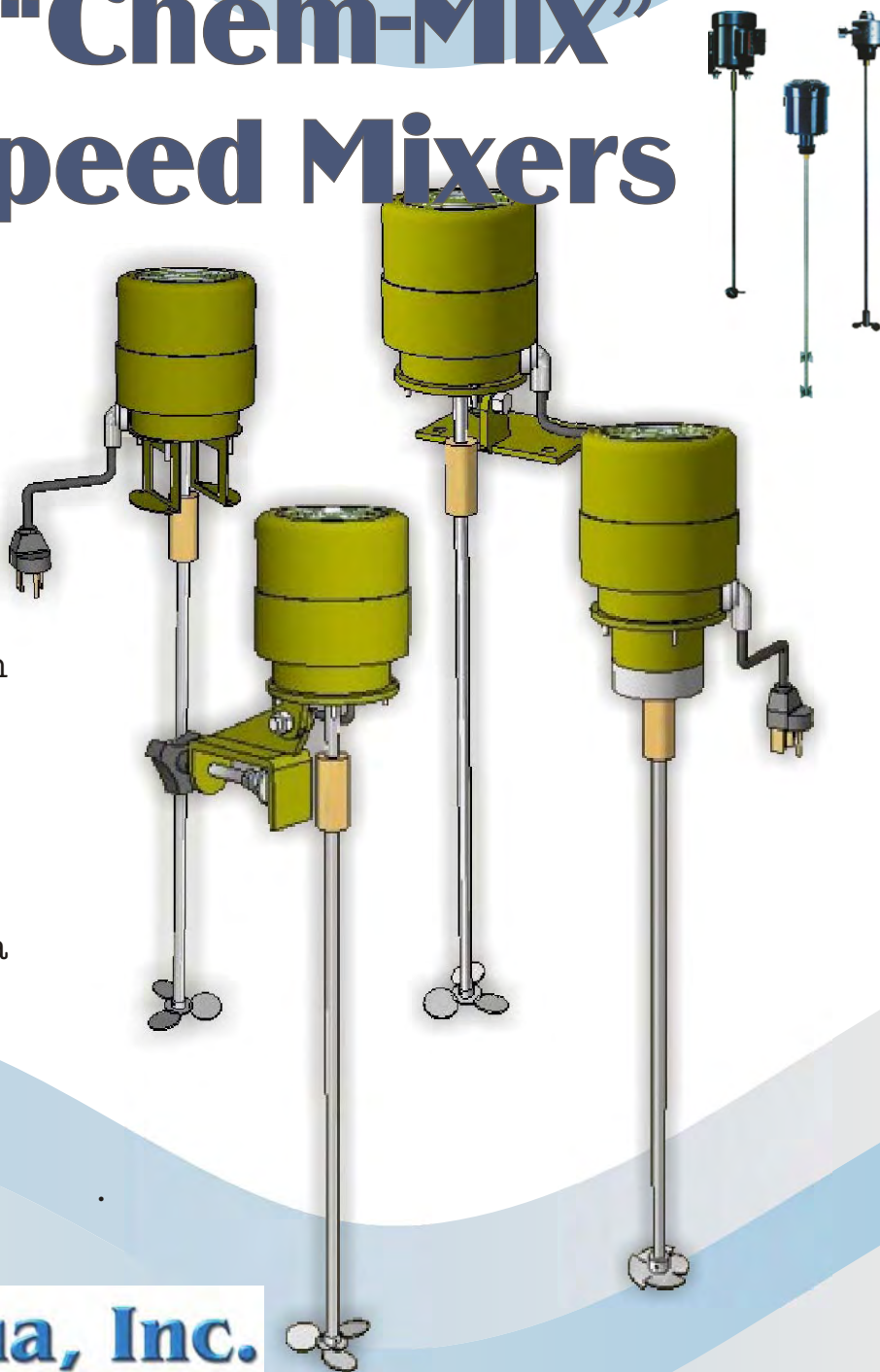

“Chem-Mix” High Speed Mixers

These rugged and reliable industrial high speed chemical batch mixers are designed for convenient installation in all types of applications. With an array of mounting configurations, horse power selections and a complete accessory offering **High Speed Mixers** are a smart way to complete any chemical batching application.



High Speed Mixers

- ★ 1/70 to 2 Horse Power Range
- ★ Four Standard Mounting Configurations (Clamp, Bracket, Flange and Thread)
- ★ Factory Pre-wired
- ★ 316SS Shaft Assemblies
- ★ Stainless Steel Hardware
- ★ 2 Year Warranty

Optional Features:

- ★ Stainless Steel Coupling
- ★ Pump Suction Tube Shield
- ★ "Green" Epoxy Coating
- ★ Control Panel
- ★ On/Off Switch
- ★ "OEM" Versions

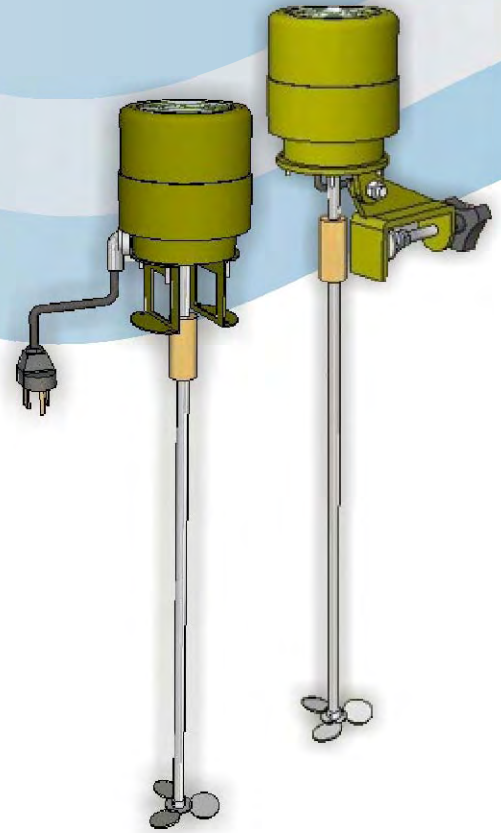

Mixers come standard with 220V or 110V power cords

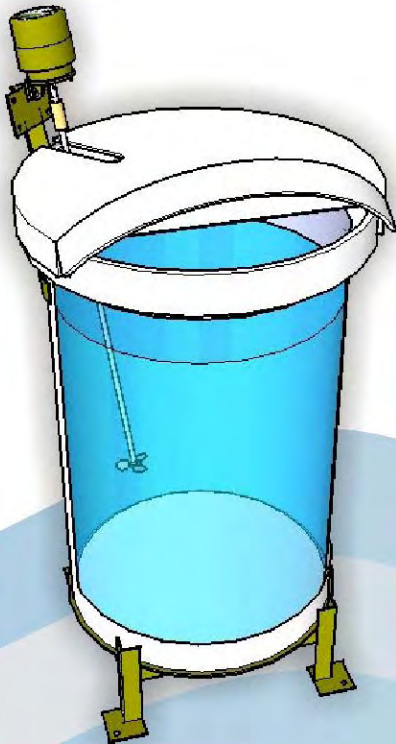

Mixing applications should not be a problem

